

*Pure Freude
an Wasser*



SMART DESIGN,
ELEVATED HYGIENE
GROHE IGINA



PART OF **LIXIL**



The IGINA Shower Toilet crafted with the best of GROHE technology embodies hygiene, design, and comfort. Derived from the word 'hygiene', IGINA is true to its name and exemplifies the architectural lines in the design with cutting-edge technologies that elevate the bathroom experience.

IGINA Shower Toilet integrates the latest technologies into its streamline chassis to prioritize hygiene for users. A protective glaze fired into the ceramicware of the toilet, HyperClean, effectively inhibits 99.9% of

bacteria growth. On top of that, AquaCeramic coated within the bowl offers the ultimate protection against any stain and waste build-up. The sleek Auto Open and Close ABS seat ensures minimal touch points and the highest anti-bacterial protection. In the promise of greater comfort and convenience, this function pairs up seamlessly with auto flushing using intelligent motion detection technology.

We can expect the best of form and functions from the luxurious IGINA Shower Toilet at greater value and never look back again.

SEAMLESS SIMPLICITY, INTUITIVELY YOURS

The simplicity of shape creates a harmonious synergy between bathroom spaces and complements the GROHE suite of products. The slim profile and full-skirted design cast a light and sleek silhouette. Paired with the one-hand grip and one-finger control, it captures the essence of an intuitive user interface where users can activate the desired functions effortlessly.



01 DESIGNED FOR HYGIENE



**Light-weighted Look
and Levitating Effect**
with the stepped bottom surface



Sophisticated and Sleek Design
with full-skirted bowl and slim seat & cover

Modern and Transitional Flawless
with integrated smooth top surface



02 DESIGNED FOR USABILITY



One-hand Grip and One-finger Control

Care for User Interface

Button layout is designed for the frequency and user's behaviors through their toilet journey

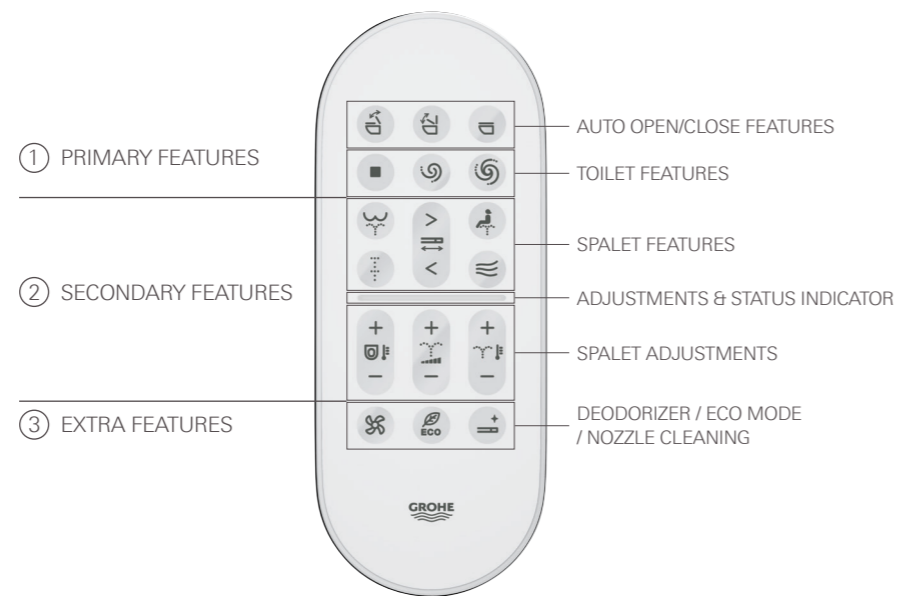

03 DESIGNED FOR COMPLETE BATHROOM

Coordinated Lozenge & Round Design from Toilet, Remote Control and Bathroom Fittings



BEYOND CLEAN, GENTLE ON SKIN

01 ULTIMATE HYGIENE

With leading-edge AquaCeramics technology, germ-resistant HyperClean coating and self-cleaning, anti-bacterial spray arms you can be certain of 100% hygiene security.



TWIN SHOWER ARM

With one spray arm for the rear spray and a separate spray arm for the lady shower, you can be certain that both are perfectly hygienic and positioned perfectly to suit your needs.



NOZZLE GUARD

The spray arms are protected behind a nozzle guard for total hygiene.



SELF CLEANING SPRAY ARM

Before and after each use, the automatic cleaning programme will run so you can have complete confidence that the spray arms and nozzles are clean and safe.



EXCHANGABLE SPRAY HEAD

Keep that safe feeling for years with the option to replace the spray head completely if needed.



ANTI-BACTERIA SEAT & SPRAY ARMS

The seat is made from 99.9% anti-bacterial material, certified by SIAA Kohkin Japanese standard. So it remains germ-free at all times.



Ceramic materials proudly feature the SIAA (Society of Industrial Technology for Antimicrobial Articles) brand mark based on ISO for KOHKIN – stringent criteria for the anti-bacterial effect and the safety of the agent.



TRIPLE VORTEX FLUSH

Three water outlets create a powerful vortex effect with each flush, covering and cleaning every corner of the bowl for ultimate hygiene.



AQUACERAMIC

Creates a smooth hydrophilic layer on the ceramic surface that dirt and limescale can't stick to, meaning there are no residues after flushing. Makes your toilet 100 years clean!



HYPERCLEAN

This exceptionally smooth and hardwearing glaze uses silver ions to prevent 99.9% of bacteria growth, keeping your ceramic sparkling clean and germ-free.



02 CONVENIENCE IN STYLE

With features such as odour absorption, air dryer, automatic seat open & close, and intuitive remote control, we offer the convenience in style.



**AUTOMATIC SEAT
OPEN & CLOSE**

When approaching the toilet, a sensor recognises your presence and the lid and seat open and close automatically.



**AUTOMATIC
FLUSH**

The moment you move away from the toilet, a sensor-controlled flush is actuated.



**ODOUR
ABSORPTION**

As soon as you sit down on the seat, odour extraction is activated automatically.



**AIR
DRYER**

After a warm-water shower, the warm-air dryer provides fast and gentle drying.



**HEATED
SEAT**

Ensure comfortable experience even in cold weather



**ONE-HAND GRIP
AND ONE-FINGER
CONTROLLING**

Access all functions by remote control, comfortably and intuitively.

03 PERSONALISED COMFORT

With a selection of fully adjustable sprays, anti-bacterial twin shower arms and unlimited warm water for comfortable cleaning we offer personalised comfort.



REAR SPRAY

Warm or cold, strong or gentle, an adjustable spray for precise and ultimate cleaning without getting wet all over. Choose between the powerful rear spray and a soft spray for more gentle cleaning.



LADY SPRAY

A separate spray arm with different spray angle and a softer and wider spray pattern for cleaning the female intimate area, with adjustable temperature and strength for total comfort and gentle cleansing.



REAR MASSAGE SPRAY

The massage spray allows you to alternate between soft and strong spray strength – for a soothing pulsating massage effect.



ADJUSTABLE SHOWER ARM

Reposition the spray arms as required.



ADJUSTABLE SHOWER PRESSURE

Adjust the spray strength to suit your needs.



UNLIMITED WARM WATER SUPPLY

An instant heater inside guarantees limitless warm water for the spray functions.



PRODUCT SPECIFICATION

IGINA Floor Standing

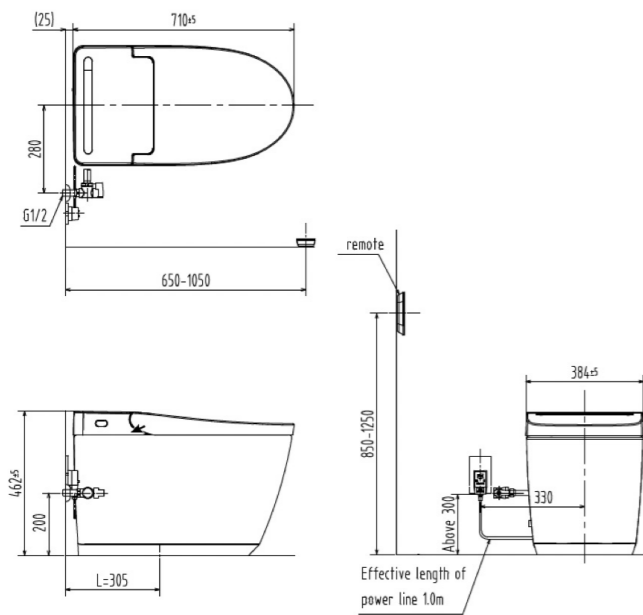

Feature	Description	IGINA Floor Standing		
	SKU	36542SH0	35543SH0	
Feature	Plug Type	Type O	Type F	
	Dimensions	710 (L) x 384 (W) x 462 (H) mm		
	Flushing System	Siphon Jet		
	Rough-in	305 mm		
	Flushing Capacity	3.5/5L		
	Water Pressure	0.08-0.8 MPa Static Pressure		
	Hygiene	Dual Nozzle	•	
		Feminine Wash	• (Remote Control)	
Posterior Wash		• (Remote Control)		
Exchangeable Shower Nozzle		•		
Antibacterial Material (Seat)		• (SIAA Certified)		
AquaCeramic + HyperClean		•		
Self Cleaning Nozzles		•		
Rimless		•		
Comfort	Auto Flush	•		
	Auto Open & Close	•		
	Instant Water Heating	•		
	Remote Control	•		
	Quick Release Lid	•		
	Dryer	•		
	Deodorizer / Odour Absorption	•		
	Heated Seat	•		
	Seat Temp. Adjustment	• 5 Levels (Adjust by +/-)		
	Spray Strength Adjustment	• 5 Levels (Adjust by +/-)		
	Water Temp. Adjustment	• 5 Levels (Adjust by +/-)		
	Nozzle Position Adjustment	• 5 Levels (Adjust by </>)		

IGINA Wall Hung

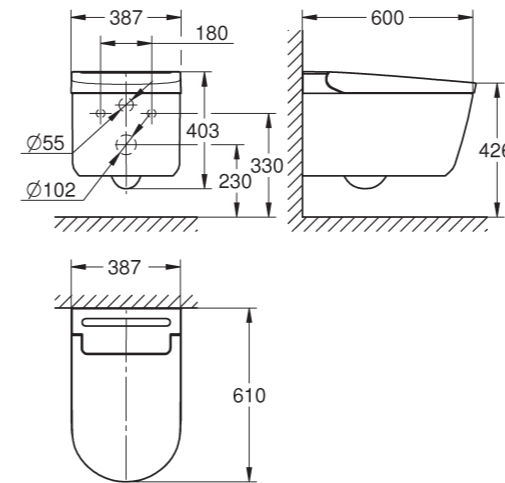

Feature	Description	IGINA Wall Hung without Auto Open & Close		IGINA Wall Hung with Auto Open & Close		
	SKU	36552SH0	102914SH00	36553SH0	102915SH00	
Feature	Plug Type	Direct-connection through a cable socket				
	Dimensions	610 (L) x 387 (W) x 403 (H) mm				
	Flushing System	Triple Vortex Platform				
	Flushing Capacity	3.5/5L	3/5L	3.5/5L	3/5L	
	Water Pressure	0.05-1.0 MPa Static Pressure				
	Hygiene	Dual Nozzle	•			
		Feminine Wash	• (Remote Control)			
Posterior Wash		• (Remote Control)				
Exchangeable Shower Nozzle		•				
Antibacterial Material (Seat)		• (SIAA Certified)				
AquaCeramic + HyperClean		•				
Self Cleaning Nozzles		•				
Rimless		•				
Comfort	Auto Flush	*Optional				
	Auto Open & Close	-		•		
	Instant Water Heating	•				
	Remote Control	•				
	Quick Release Lid	•				
	Dryer	•				
	Deodorizer / Odour Absorption	•				
	Heated Seat	•				
	Seat Temp. Adjustment	• 5 Levels (Adjust by +/-)				
	Spray Strength Adjustment	• 5 Levels (Adjust by +/-)				
	Water Temp. Adjustment	• 5 Levels (Adjust by +/-)				
	Nozzle Position Adjustment	• 5 Levels (Adjust by </>)				

* Remote control automatic flush kit (SKU# - 1029950200) is needed

** Recommended cistern tank: GROHE Rapid SLX (SKU# - 39596000)

Follow us



QUALITY

*"No.1 most trusted brand
in the sanitary industry"*

—
Wirtschaftswoche, 2017

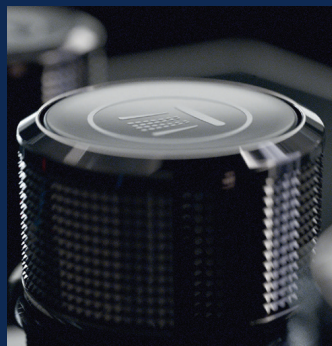

TECHNOLOGY

*"Top 50 companies
to change the world"*

—
Fortune Magazine, 2017



DESIGN

*Over
613 design awards
won since 2003*

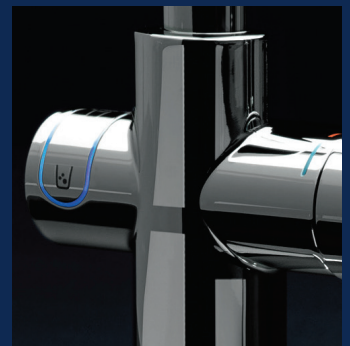

SUSTAINABILITY

*CSR Award winner
of the German Government,
2017*

GROHE Australia:
Tel: (61) 3 9274 0222
www.grohe.com.au

GROHE Cambodia:
Tel: (855) 92 504 736
www.grohe.kh

GROHE India:
Tel: (91) 124 493 3000
www.grohe.co.in

GROHE Indonesia:
Tel: (62) 21 2966 0296
www.grohe.co.id

GROHE Korea:
Tel: (82) 1588 5903
www.grohe.kr

GROHE Malaysia:
Tel: (60) 1800 80 6570
www.grohe.my

GROHE Myanmar:
Tel: (959) 2 5337 3070
www.grohe.com

GROHE New Zealand:
Tel: (64) 9573 0490
www.grohe.nz

GROHE Philippines:
Tel: (63) 2 893 3113/1620
www.grohe.ph

GROHE Singapore:
Tel: (65) 6311 3611
www.grohe.sg

GROHE Taiwan:
Tel: (886) 2 8712 1877
www.grohe.tw

GROHE Thailand:
Tel: (66) 2901 4455
www.grohe.co.th

GROHE Vietnam:
Tel: 1800 6624
www.grohe.com.vn